

Soudax

Pneumatic connection of the EV and PV

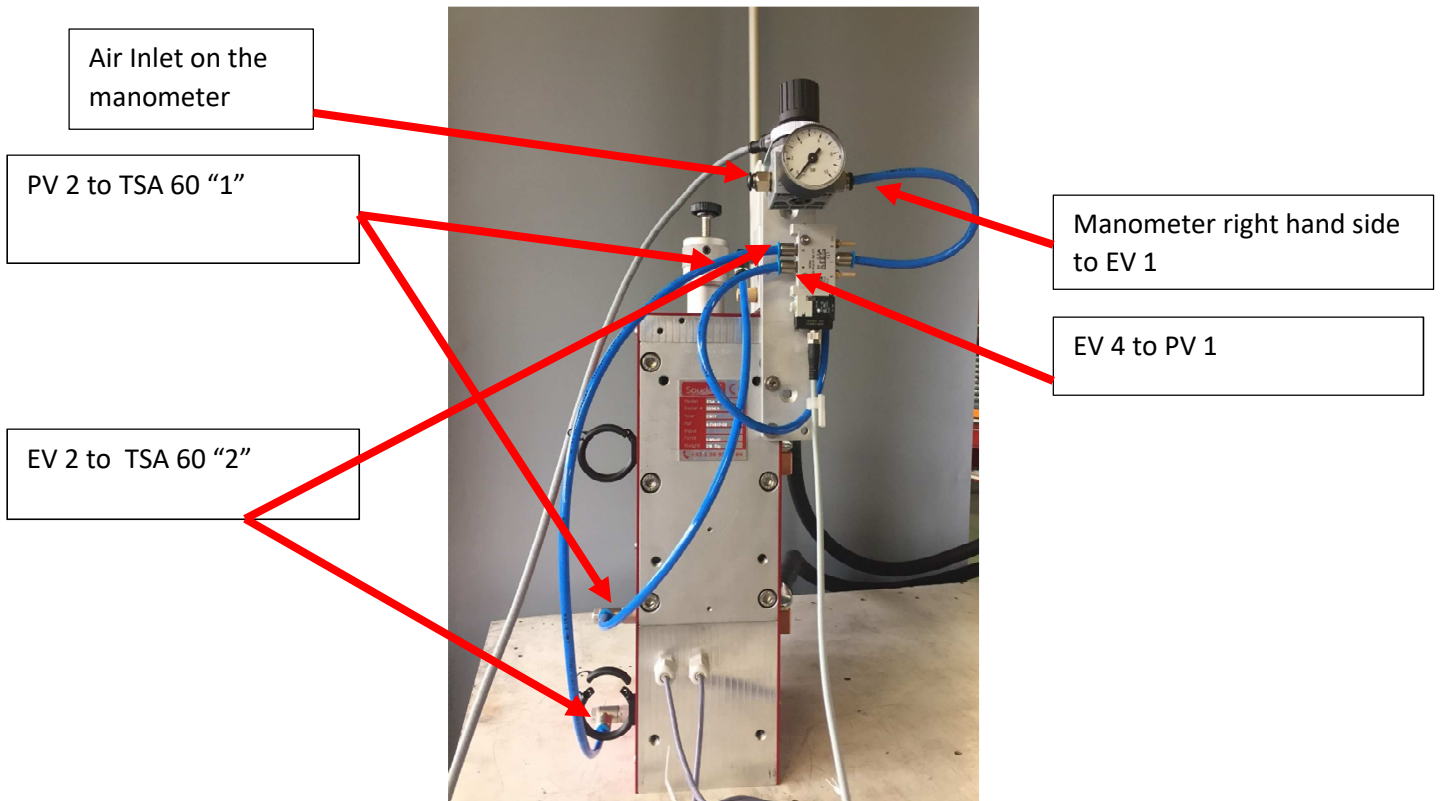

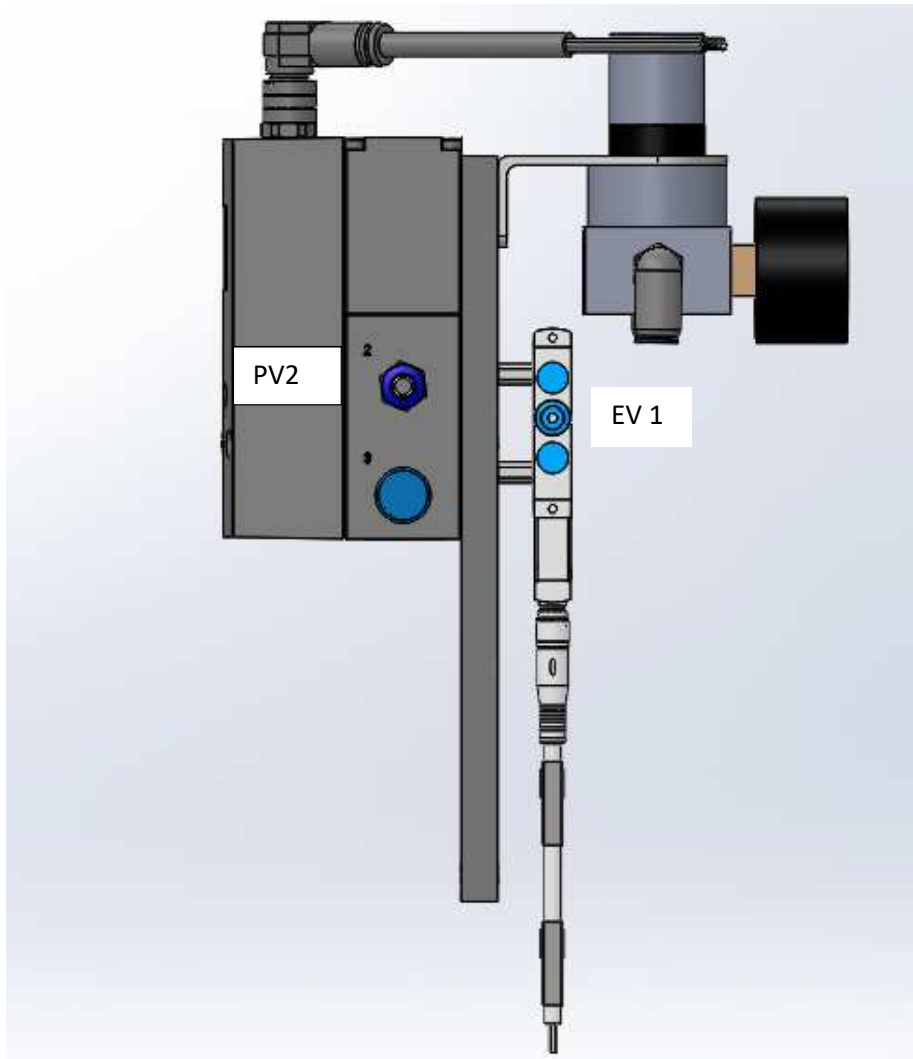

Manometer (right hand side) to EV1
PV1 to EV 4
EV2 to TSA 1
PV2 to TSA 2

